



23

TRIGONOMETRIC RATIOS OF SOME SPECIAL ANGLES

In the last lesson, we have defined trigonometric ratios for acute angles in a right triangle and also developed some relationship between them. In this lesson we shall find the values of trigonometric ratios of angles of 30° , 45° and 60° by using our knowledge of geometry. We shall also write the values of trigonometric ratios of 0° and 90° and we shall observe that some trigonometric ratios of 0° and 90° are not defined. We shall also use the knowledge of trigonometry to solve simple problems on heights and distances from day to day life.



OBJECTIVES

After studying this lesson, you will be able to

- find the values of trigonometric ratios of angles of 30° , 45° and 60° ;
- write the values of trigonometric ratios of 0° and 90° ;
- tell, which trigonometric ratios of 0° and 90° are not defined;
- solve daily life problems of heights and distances;

EXPECTED BACKGROUND KNOWLEDGE

- Pythagoras Theorem i.e. in a right angled triangle ABC, right angled at B,
 $AC^2 = AB^2 + BC^2$.
- In a right triangle ABC, right angled at B,

$$\sin C = \frac{\text{side opposite to } \angle C}{\text{Hypotenuse}}, \quad \operatorname{cosec} C = \frac{\text{Hypotenuse}}{\text{side opposite to } \angle C}$$

$$\cos C = \frac{\text{side adjacent to } \angle C}{\text{Hypotenuse}}, \quad \sec C = \frac{\text{Hypotenuse}}{\text{side adjacent to } \angle C}$$



Notes

$$\tan C = \frac{\text{side opposite to } \angle C}{\text{side adjacent to } \angle C} \text{ and } \cot C = \frac{\text{side adjacent to } \angle C}{\text{side opposite to } \angle C}$$

$$\operatorname{cosec} C = \frac{1}{\sin C}, \sec C = \frac{1}{\cos C} \text{ and } \cot C = \frac{1}{\tan C}$$

- $\sin (90^\circ - \theta) = \cos \theta, \cos (90^\circ - \theta) = \sin \theta$
 $\tan (90^\circ - \theta) = \cot \theta, \cot (90^\circ - \theta) = \tan \theta$
- $\sec (90^\circ - \theta) = \operatorname{cosec} \theta$ and $\operatorname{cosec} (90^\circ - \theta) = \sec \theta$

23.1 TRIGONOMETRIC RATIOS FOR AN ANGLE OF 45°

Let a ray OA start from OX and rotate in the anticlockwise direction and make an angle of 45° with the x -axis as shown in Fig. 23.1.

Take any point P on OA. Draw $PM \perp OX$.

Now in right ΔPMO ,

$$\angle POM + \angle OPM + \angle PMO = 180^\circ$$

or $45^\circ + \angle OPM + 90^\circ = 180^\circ$

or $\angle OPM = 180^\circ - 90^\circ - 45^\circ = 45^\circ$

\therefore In $\Delta PMO, \angle OPM = \angle POM = 45^\circ$

$\therefore OM = PM$

Let $OM = a$ units, then $PM = a$ units.

In right triangle PMO,

$$OP^2 = OM^2 + PM^2 \text{ (Pythagoras Theorem)}$$

$$= a^2 + a^2$$

$$= 2 a^2$$

$\therefore OP = \sqrt{2} a$ units

Now $\sin 45^\circ = \frac{PM}{OP} = \frac{a}{\sqrt{2}a} = \frac{1}{\sqrt{2}}$

$$\cos 45^\circ = \frac{OM}{OP} = \frac{a}{\sqrt{2}a} = \frac{1}{\sqrt{2}}$$

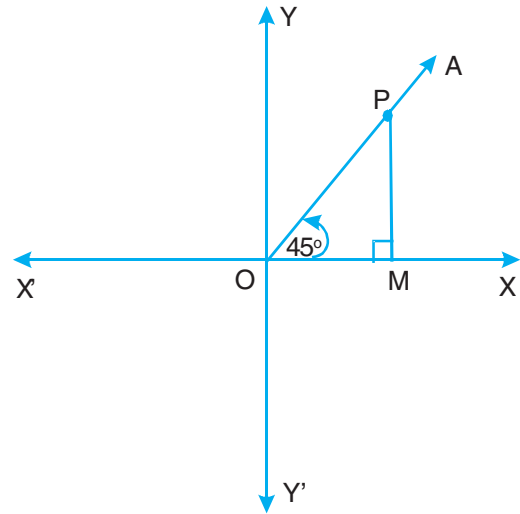

Fig. 23.1



$$\tan 45^\circ = \frac{PM}{OM} = \frac{a}{a} = 1$$

$$\operatorname{cosec} 45^\circ = \frac{1}{\sin 45^\circ} = \frac{1}{1/\sqrt{2}} = \sqrt{2}$$

$$\sec 45^\circ = \frac{1}{\cos 45^\circ} = \frac{1}{1/\sqrt{2}} = \sqrt{2}$$

and $\cot 45^\circ = \frac{1}{\tan 45^\circ} = \frac{1}{1} = 1$

23.2 TRIGONOMETRIC RATIOS FOR AN ANGLE OF 30°

Let a ray OA start from OX and rotate in the anti clockwise direction and make an angle of 30° with x-axis as shown in Fig. 23.2.

Take any point P on OA.

Draw $PM \perp OX$ and produce

PM to P' such that $PM = P'M$. Join OP'

Now in $\triangle PMO$ and $\triangle P'MO$,

$$OM = OM \quad \dots(\text{Common})$$

$$\angle PMO = \angle P'MO \quad \dots(\text{Each} = 90^\circ)$$

and $PM = P'M \quad \dots(\text{Construction})$

$$\therefore \triangle PMO \cong \triangle P'MO$$

$$\therefore \angle OPM = \angle OP'M = 60^\circ$$

\therefore OPP' is an equilateral triangle

$$\therefore OP = OP'$$

Let $PM = a$ units

$$PP' = PM + MP'$$

$$= (a + a) \text{ units} \quad \dots(\because MP' = MP)$$

$$= 2a \text{ units}$$

$$\therefore OP = OP' = PP' = 2a \text{ units}$$

Now in right triangle PMO,

$$OP^2 = PM^2 + OM^2 \quad \dots(\text{Pythagoras Theorem})$$

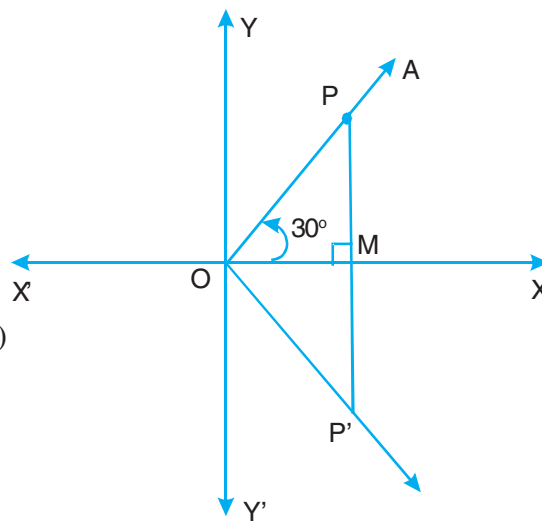

Fig. 23.2



or $(2a)^2 = a^2 + OM^2$

$\therefore OM^2 = 3a^2$

or $OM = \sqrt{3} a$ units

$\therefore \sin 30^\circ = \frac{PM}{OP} = \frac{a}{2a} = \frac{1}{2}$

$\cos 30^\circ = \frac{OM}{OP} = \frac{\sqrt{3}a}{2a} = \frac{\sqrt{3}}{2}$

$\tan 30^\circ = \frac{PM}{OM} = \frac{a}{\sqrt{3}a} = \frac{1}{\sqrt{3}}$

$\operatorname{cosec} 30^\circ = \frac{1}{\sin 30^\circ} = \frac{1}{1/2} = 2$

$\sec 30^\circ = \frac{1}{\cos 30^\circ} = \frac{1}{\sqrt{3}/2} = \frac{2}{\sqrt{3}}$

and $\cot 30^\circ = \frac{1}{\tan 30^\circ} = \frac{1}{1/\sqrt{3}} = \sqrt{3}$

23.3 TRIGONOMETRIC RATIOS FOR AN ANGLE OF 60°

Let a ray OA start from OX and rotate in anticlockwise direction and make an angle of 60° with x-axis.

Take any point P on OA.

Draw $PM \perp OX$.

Produce OM to M' such that

$OM = MM'$. Join PM'.

Let $OM = a$ units

In ΔPMO and $\Delta PMM'$,

$PM = PM$... (Common)

$\angle PMO = \angle PMM'$... (Each = 90°)

$OM = MM'$... (Construction)

$\therefore \Delta PMO \cong \Delta PMM'$

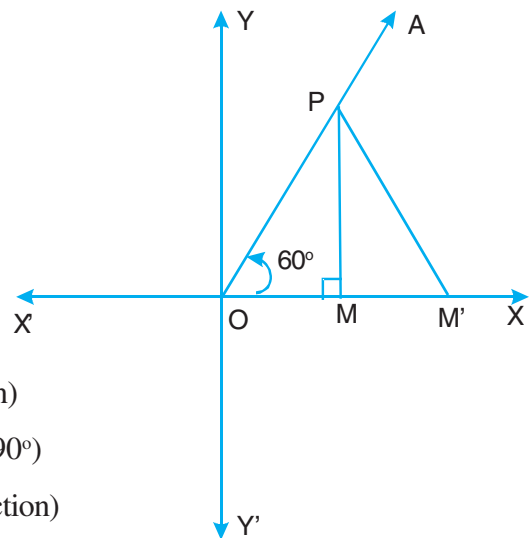

Fig. 23.3



$$\therefore \angle POM = \angle PM'M = 60^\circ$$

$\therefore \Delta POM'$ is an equilateral triangle.

$$\therefore OP = PM' = OM' = 2a \text{ units}$$

In right ΔPMO ,

$$OP^2 = PM^2 + OM^2 \quad \dots(\text{Pythagorus Theorem})$$

$$\therefore (2a)^2 = PM^2 + a^2$$

$$\text{or } PM^2 = 3a^2$$

$$\therefore PM = \sqrt{3} a \text{ units}$$

$$\therefore \sin 60^\circ = \frac{PM}{OP} = \frac{\sqrt{3}a}{2a} = \frac{\sqrt{3}}{2}$$

$$\cos 60^\circ = \frac{OM}{OP} = \frac{a}{2a} = \frac{1}{2}$$

$$\tan 60^\circ = \frac{PM}{OM} = \frac{\sqrt{3}a}{a} = \sqrt{3}$$

$$\operatorname{cosec} 60^\circ = \frac{1}{\sin 60^\circ} = \frac{1}{\frac{\sqrt{3}}{2}} = \frac{2}{\sqrt{3}}$$

$$\sec 60^\circ = \frac{1}{\cos 60^\circ} = \frac{1}{1/2} = 2$$

$$\text{and } \cot 60^\circ = \frac{1}{\tan 60^\circ} = \frac{1}{\sqrt{3}}$$

23.4 TRIGONOMETRIC RATIOS FOR ANGLES OF 0° AND 90°

In Section 23.1, 23.2 and 23.3, we have defined trigonometric ratios for angles of 45° , 30° and 60° . For angles of 0° and 90° , we shall assume the following results and we shall not be discussing the logical proofs of these.

(i) $\sin 0^\circ = 0$ and therefore $\operatorname{cosec} 0^\circ$ is not defined

(ii) $\cos 0^\circ = 1$ and therefore $\sec 0^\circ = 1$



Notes

- (iii) $\tan 0^\circ = 0$ therefore $\cot 0^\circ$ is not defined.
- (iv) $\sin 90^\circ = 1$ and therefore $\operatorname{cosec} 90^\circ = 1$
- (v) $\cos 90^\circ = 0$ and therefore $\sec 90^\circ$ is not defined.
- (vi) $\cot 90^\circ = 0$ and therefore $\tan 90^\circ$ is not defined.

The values of trigonometric ratios for $0^\circ, 30^\circ, 45^\circ, 60^\circ$ and 90° can be put in a tabular form which makes their use simple. The following table also works as an aid to memory.

θ	0°	30°	45°	60°	90°
Trig. ratio					
$\sin \theta$	$\sqrt{\frac{0}{4}} = 0$	$\sqrt{\frac{1}{4}} = \frac{1}{2}$	$\sqrt{\frac{2}{4}} = \frac{1}{\sqrt{2}}$	$\sqrt{\frac{3}{4}} = \frac{\sqrt{3}}{2}$	$\sqrt{\frac{4}{4}} = 1$
$\cos \theta$	$\sqrt{\frac{4}{4}} = 1$	$\sqrt{\frac{3}{4}} = \frac{\sqrt{3}}{2}$	$\sqrt{\frac{2}{4}} = \frac{1}{\sqrt{2}}$	$\sqrt{\frac{1}{4}} = \frac{1}{2}$	$\sqrt{\frac{0}{4}} = 0$
$\tan \theta$	$\sqrt{\frac{0}{4-0}} = 0$	$\sqrt{\frac{1}{4-1}} = \frac{1}{\sqrt{3}}$	$\sqrt{\frac{2}{4-2}} = 1$	$\sqrt{\frac{3}{4-3}} = \sqrt{3}$	Not defined
$\cot \theta$	Not defined	$\sqrt{\frac{3}{4-3}} = \sqrt{3}$	$\sqrt{\frac{2}{4-2}} = 1$	$\sqrt{\frac{1}{4-1}} = \frac{1}{\sqrt{3}}$	$\sqrt{\frac{0}{4-0}} = 0$
$\operatorname{cosec} \theta$	Not defined	$\sqrt{\frac{4}{1}} = 2$	$\sqrt{\frac{4}{2}} = \sqrt{2}$	$\sqrt{\frac{4}{3}} = \frac{2}{\sqrt{3}}$	$\sqrt{\frac{4}{4}} = 1$
$\sec \theta$	$\sqrt{\frac{4}{4}} = 1$	$\sqrt{\frac{4}{3}} = \frac{2}{\sqrt{3}}$	$\sqrt{\frac{4}{2}} = \sqrt{2}$	$\sqrt{\frac{4}{1}} = 2$	Not defined

Let us, now take some examples to illustrate the use of these trigonometric ratios.

Example 23.1: Find the value of $\tan^2 60^\circ - \sin^2 30^\circ$.

Solution: We know that $\tan 60^\circ = \sqrt{3}$ and $\sin 30^\circ = \frac{1}{2}$

$$\begin{aligned} \therefore \tan^2 60^\circ - \sin^2 30^\circ &= (\sqrt{3})^2 - \left(\frac{1}{2}\right)^2 \\ &= 3 - \frac{1}{4} = \frac{11}{4} \end{aligned}$$



Example 23.2: Find the value of

$$\cot^2 30^\circ \sec^2 45^\circ + \operatorname{cosec}^2 45^\circ \cos 60^\circ$$

Solution: We know that

$$\cot 30^\circ = \sqrt{3}, \sec 45^\circ = \sqrt{2}, \operatorname{cosec} 45^\circ = \sqrt{2} \text{ and } \cos 60^\circ = \frac{1}{2}$$

$$\therefore \cot^2 30^\circ \sec^2 45^\circ + \operatorname{cosec}^2 45^\circ \cos 60^\circ$$

$$= (\sqrt{3})^2 (\sqrt{2})^2 + (\sqrt{2})^2 \cdot \frac{1}{2}$$

$$= 3 \times 2 + 2 \times \frac{1}{2}$$

$$= 6 + 1$$

$$= 7$$

Example 23.3: Evaluate : $2(\cos^2 45^\circ + \tan^2 60^\circ) - 6(\sin^2 45^\circ - \tan^2 30^\circ)$

Solution: $2(\cos^2 45^\circ + \tan^2 60^\circ) - 6(\sin^2 45^\circ - \tan^2 30^\circ)$

$$= 2 \left[\left(\frac{1}{\sqrt{2}} \right)^2 + (\sqrt{3})^2 \right] - 6 \left[\left(\frac{1}{\sqrt{2}} \right)^2 - \left(\frac{1}{\sqrt{3}} \right)^2 \right]$$

$$= 2 \left(\frac{1}{2} + 3 \right) - 6 \left(\frac{1}{2} - \frac{1}{3} \right)$$

$$= 1 + 6 - 3 + 2$$

$$= 6$$

Example 23.4: Verify that

$$\frac{\tan 45^\circ}{\operatorname{cosec} 30^\circ} + \frac{\sec 60^\circ}{\cot 45^\circ} - \frac{5 \sin 90^\circ}{2 \cos 0^\circ} = 0$$

Solution: L.H.S. = $\frac{\tan 45^\circ}{\operatorname{cosec} 30^\circ} + \frac{\sec 60^\circ}{\cot 45^\circ} - \frac{5 \sin 90^\circ}{2 \cos 0^\circ}$

$$= \frac{1}{2} + \frac{2}{1} - \frac{5 \times 1}{2 \times 1}$$

$$= \frac{1}{2} + 2 - \frac{5}{2} = 0 = \text{R.H.S.}$$



Notes

Hence, $\frac{\tan 45^\circ}{\operatorname{cosec} 30^\circ} + \frac{\sec 60^\circ}{\cot 45^\circ} - \frac{5 \sin 90^\circ}{2 \cos 0^\circ} = 0$

Example 23.5: Show that

$$\frac{4}{3} \cot^2 30^\circ + 3 \sin^2 60^\circ - 2 \operatorname{cosec}^2 60^\circ - \frac{3}{4} \tan^2 30^\circ = \frac{10}{3}$$

Solution: L.H.S. = $\frac{4}{3} \cot^2 30^\circ + 3 \sin^2 60^\circ - 2 \operatorname{cosec}^2 60^\circ - \frac{3}{4} \tan^2 30^\circ$

$$= \frac{4}{3} \times (\sqrt{3})^2 + 3 \left(\frac{\sqrt{3}}{2} \right)^2 - 2 \left(\frac{2}{\sqrt{3}} \right)^2 - \frac{3}{4} \left(\frac{1}{\sqrt{3}} \right)^2$$

$$= \frac{4}{3} \times 3 + 3 \times \frac{3}{4} - 2 \times \frac{4}{3} - \frac{3}{4} \times \frac{1}{3}$$

$$= 4 + \frac{9}{4} - \frac{8}{3} - \frac{1}{4}$$

$$= \frac{48 + 27 - 32 - 3}{12}$$

$$= \frac{40}{12} = \frac{10}{3}$$

= R.H.S.

Hence, $\frac{4}{3} \cot^2 30^\circ + 3 \sin^2 60^\circ - 2 \operatorname{cosec}^2 60^\circ - \frac{3}{4} \tan^2 30^\circ = \frac{10}{3}$

Example 23.6: Verify that

$$\frac{4 \cot^2 60^\circ + \sec^2 30^\circ - 2 \sin^2 45^\circ}{\cos^2 30^\circ + \cos^2 45^\circ} = \frac{4}{3}$$

Solution: L.H.S. = $\frac{4 \cot^2 60^\circ + \sec^2 30^\circ - 2 \sin^2 45^\circ}{\cos^2 30^\circ + \cos^2 45^\circ}$

$$= \frac{4 \left(\frac{1}{\sqrt{3}} \right)^2 + \left(\frac{2}{\sqrt{3}} \right)^2 - 2 \left(\frac{1}{\sqrt{2}} \right)^2}{\left(\frac{\sqrt{3}}{2} \right)^2 + \left(\frac{1}{\sqrt{2}} \right)^2}$$



Notes

$$= \frac{4 \times \frac{1}{3} + \frac{4}{3} - 2 \times \frac{1}{2}}{\frac{3}{4} + \frac{1}{2}}$$

$$= \frac{\frac{8}{3} - 1 + \frac{5}{3}}{\frac{4}{4}} = \frac{3}{5}$$

$$= \frac{5}{3} \times \frac{4}{5} = \frac{4}{3}$$

= R.H.S.

Hence, $\frac{4 \cot^2 60^\circ + \sec^2 30^\circ - 2 \sin^2 45^\circ}{\cos^2 30^\circ + \cos^2 45^\circ} = \frac{4}{3}$

Example 23.7: If $\theta = 30^\circ$, verify that

$$\tan 2\theta = \frac{2 \tan \theta}{1 - \tan^2 \theta}$$

Solution: For $\theta = 30^\circ$

$$\begin{aligned} \text{L.H.S.} &= \tan 2\theta \\ &= \tan (2 \times 30^\circ) \\ &= \tan 60^\circ \\ &= \sqrt{3} \end{aligned}$$

$$\begin{aligned} \text{and R.H.S.} &= \frac{2 \tan \theta}{1 - \tan^2 \theta} \\ &= \frac{2 \tan 30^\circ}{1 - \tan^2 30^\circ} \\ &= \frac{2 \cdot \left(\frac{1}{\sqrt{3}}\right)}{1 - \left(\frac{1}{\sqrt{3}}\right)^2} \end{aligned}$$



$$= \frac{\frac{2}{\sqrt{3}}}{1 - \frac{1}{3}} = \frac{\frac{2}{\sqrt{3}}}{\frac{2}{3}}$$

$$= \frac{2}{\sqrt{3}} \times \frac{3}{2} = \sqrt{3}$$

∴ L.H.S. = R.H.S.

Hence, $\tan 2\theta = \frac{2 \tan \theta}{1 - \tan^2 \theta}$

Example 23.8: Let $A = 30^\circ$. Verify that

$$\sin 3A = 3 \sin A - 4 \sin^3 A$$

Solution: For $A = 30^\circ$,

$$\begin{aligned} \text{L.H.S.} &= \sin 3A \\ &= \sin (3 \times 30^\circ) \\ &= \sin 90^\circ \\ &= 1 \end{aligned}$$

$$\begin{aligned} \text{and R.H.S.} &= 3 \sin A - 4 \sin^3 A \\ &= 3 \sin 30^\circ - 4 \sin^3 30^\circ \\ &= 3 \times \frac{1}{2} - 4 \times \left(\frac{1}{2}\right)^3 \end{aligned}$$

$$= \frac{3}{2} - \frac{4}{8}$$

$$= \frac{3}{2} - \frac{1}{2}$$

$$= 1$$

∴ L.H.S. = R.H.S.

Hence, $\sin 3A = 3 \sin A - 4 \sin^3 A$

Example 23.9: Using the formula $\sin (A - B) = \sin A \cos B - \cos A \sin B$, find the value of $\sin 15^\circ$.



Solution: $\sin(A - B) = \sin A \cos B - \cos A \sin B$... (i)

Let $A = 45^\circ$ and $B = 30^\circ$

\therefore From (i),

$$\sin(45^\circ - 30^\circ) = \sin 45^\circ \cos 30^\circ - \cos 45^\circ \sin 30^\circ$$

or $\sin 15^\circ = \frac{1}{\sqrt{2}} \times \frac{\sqrt{3}}{2} - \frac{1}{\sqrt{2}} \times \frac{1}{2}$

$$= \frac{\sqrt{3} - 1}{2\sqrt{2}}$$

Hence, $\sin 15^\circ = \frac{\sqrt{3} - 1}{2\sqrt{2}}$.

Remark: In the above examples we can also take $A = 60^\circ$ and $B = 45^\circ$.

Example 23.10: If $\sin(A + B) = 1$ and $\cos(A - B) = 1$, $0^\circ < A + B \leq 90^\circ$, $A \geq B$, find A and B.

Solution: $\therefore \sin(A + B) = 1 = \sin 90^\circ$

$\therefore A + B = 90^\circ$... (i)

Again $\cos(A - B) = 1 = \cos 0^\circ$

$\therefore A - B = 0^\circ$... (ii)

Adding (i) and (ii), we get

$$2A = 90^\circ \text{ or } A = 45^\circ$$

From (ii), we get

$$B = A = 45^\circ$$

Hence, $A = 45^\circ$ and $B = 45^\circ$

Example 23.11: If $\cos(20^\circ + x) = \sin 30^\circ$, find x.

Solution: $\cos(20^\circ + x) = \sin 30^\circ = \frac{1}{2} = \cos 60^\circ$... $\left(\because \cos 60^\circ = \frac{1}{2} \right)$

$\therefore 20^\circ + x = 60^\circ$

or $x = 60^\circ - 20^\circ = 40^\circ$

Hence, $x = 40^\circ$



Notes

Example 23.12: In $\triangle ABC$, right angled at B, if $BC = 5$ cm, $\angle BAC = 30^\circ$, find the length of the sides AB and AC.

Solution: We are given $\angle BAC = 30^\circ$ i.e., $\angle A = 30^\circ$

and $BC = 5$ cm

$$\text{Now } \sin A = \frac{BC}{AC}$$

$$\text{or } \sin 30^\circ = \frac{5}{AC}$$

$$\text{or } \frac{1}{2} = \frac{5}{AC}$$

$$\therefore AC = 2 \times 5 \text{ or } 10 \text{ cm}$$

By Pythagoras Theorem,

$$\begin{aligned} AB &= \sqrt{AC^2 - BC^2} \\ &= \sqrt{(10)^2 - 5^2} \text{ cm} \\ &= \sqrt{75} \text{ cm} \\ &= 5\sqrt{3} \text{ cm} \end{aligned}$$

Hence $AC = 10$ cm and $AB = 5\sqrt{3}$ cm.

Example 23.13: In $\triangle ABC$, right angled at C, $AC = 4$ cm and $AB = 8$ cm. Find $\angle A$ and $\angle B$.

Solution: We are given, $AC = 4$ cm and $AB = 8$ cm

$$\begin{aligned} \text{Now } \sin B &= \frac{AC}{AB} \\ &= \frac{4}{8} \text{ or } \frac{1}{2} \end{aligned}$$

$$\therefore B = 30^\circ \quad \dots \left[\because \sin 30^\circ = \frac{1}{2} \right]$$

$$\text{Now } \angle A = 90^\circ - \angle B \quad \dots \left[\because \angle A + \angle B = 90^\circ \right]$$

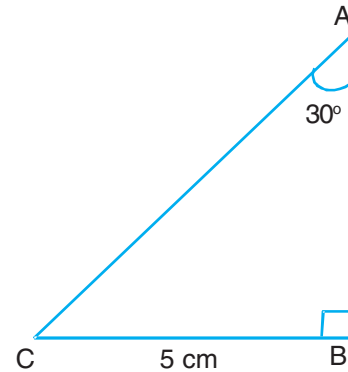

Fig. 23.4

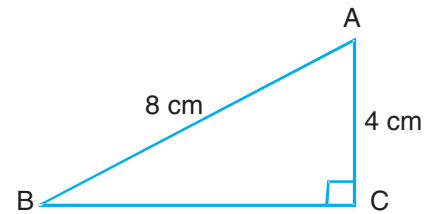

Fig. 23.5



$$= 90^\circ - 30^\circ$$

$$= 60^\circ$$

Hence, $\angle A = 60^\circ$ and $\angle B = 30^\circ$

Example 23.14: $\triangle ABC$ is right angled at B. If $\angle A = \angle C$, find the value of

(i) $\sin A \cos C + \cos A \sin C$

(ii) $\sin A \sin B + \cos A \cos B$

Solution: We are given that in $\triangle ABC$,

$$\angle B = 90^\circ$$

$$\begin{aligned} \therefore \angle A + \angle C &= 180^\circ - 90^\circ && \dots (\because \angle A + \angle B + \angle C = 180^\circ) \\ &= 90^\circ \end{aligned}$$

Also it is given that $\angle A = \angle C$

$$\therefore \angle A = \angle C = 45^\circ$$

(i) $\sin A \cos C + \cos A \sin C$

$$= \sin 45^\circ \cos 45^\circ + \cos 45^\circ \sin 45^\circ$$

$$= \frac{1}{\sqrt{2}} \times \frac{1}{\sqrt{2}} + \frac{1}{\sqrt{2}} \times \frac{1}{\sqrt{2}}$$

$$= \frac{1}{2} + \frac{1}{2} = 1$$

(ii) $\sin A \sin B + \cos A \cos B$

$$= \sin 45^\circ \sin 90^\circ + \cos 45^\circ \cos 90^\circ$$

$$= \frac{1}{\sqrt{2}} \times 1 + \frac{1}{\sqrt{2}} \times 0$$

$$= \frac{1}{\sqrt{2}}$$

Example 23.15: Find the value of x if $\tan 2x - \sqrt{3} = 0$.

Solution: We are given

$$\tan 2x - \sqrt{3} = 0$$

or $\tan 2x = \sqrt{3} = \tan 60^\circ$



Notes

$$\therefore 2x = 60^\circ$$

$$\text{or } x = 30^\circ$$

Hence value of x is 30° .



CHECK YOUR PROGRESS 23.1

1. Evaluate each of the following:

(i) $\sin^2 60^\circ + \cos^2 45^\circ$

(ii) $2 \sin^2 30^\circ - 2 \cos^2 45^\circ + \tan^2 60^\circ$

(iii) $4 \sin^2 60^\circ + 3 \tan^2 30^\circ - 8 \sin^2 45^\circ \cos 45^\circ$

(iv) $4(\sin^4 30^\circ + \cos^4 60^\circ) - 3(\cos^2 45^\circ - 2 \sin^2 45^\circ)$

(v) $\frac{\tan 45^\circ}{\operatorname{cosec} 30^\circ} + \frac{\sec 60^\circ}{\cot 45^\circ} - \frac{5 \sin 90^\circ}{2 \cos 0^\circ}$

(vi) $\frac{5 \cos^2 60^\circ + 4 \sec^2 30^\circ - \tan^2 45^\circ}{\sin^2 30^\circ + \cos^2 30^\circ}$

2. Verify each of the following:

(i) $\operatorname{cosec}^3 30^\circ \times \cos 60^\circ \times \tan^3 45^\circ \times \sin^2 90^\circ \times \sec^2 45^\circ \times \cot 30^\circ = 8\sqrt{3}$

(ii) $\tan^2 30^\circ + \frac{1}{2} \sin^2 45^\circ + \frac{1}{3} \cos^2 30^\circ + \cot^2 60^\circ = \frac{7}{6}$

(iii) $\cos^2 60^\circ - \sin^2 60^\circ = -\cos 60^\circ$

(iv) $4(\sin^4 30^\circ + \cos^4 60^\circ) - 3(\cos^2 45^\circ - \sin^2 90^\circ) = 2$

(v) $\frac{\tan 60^\circ - \tan 30^\circ}{1 + \tan 60^\circ \tan 30^\circ} = \tan 30^\circ$

3. If $\angle A = 30^\circ$, verify each of the following:

(i) $\sin 2A = \frac{2 \tan A}{1 + \tan^2 A}$

(ii) $\cos 2A = \frac{1 - \tan^2 A}{1 + \tan^2 A}$

(iii) $\cos 3A = 4 \cos^3 A - 3 \cos A$



Notes

4. If $A = 60^\circ$ and $B = 30^\circ$, verify each of the following:

(i) $\sin(A + B) = \sin A \cos B + \cos A \sin B$

(ii) $\tan(A - B) = \frac{\tan A - \tan B}{1 + \tan A \tan B}$

5. Taking $2A = 60^\circ$, find $\sin 30^\circ$ and $\cos 30^\circ$, using $\cos 2A = 2 \cos^2 A - 1$.

6. Using the formula $\cos(A + B) = \cos A \cos B - \sin A \sin B$, evaluate $\cos 75^\circ$.

7. If $\sin(A - B) = \frac{1}{2}$, $\cos(A + B) = \frac{1}{2}$, $0^\circ < A + B < 90^\circ$, $A > B$, find A and B .

8. If $\sin(A + 2B) = \frac{\sqrt{3}}{2}$ and $\cos(A + 4B) = 0$, find A and B .

9. In ΔPQR right angled at Q , $PQ = 5$ cm and $\angle R = 30^\circ$, find QR and PR .

10. In ΔABC , $\angle B = 90^\circ$, $AB = 6$ cm and $AC = 12$ cm. Find $\angle A$ and $\angle C$.

11. In ΔABC , $\angle B = 90^\circ$. If $A = 30^\circ$, find the value of $\sin A \cos B + \cos A \sin B$.

12. If $\cos(40^\circ + 2x) = \sin 30^\circ$, find x .

Choose the correct alternative for each of the following (13-15):

13. The value of $\sec 30^\circ$ is

- (A) 2 (B) $\frac{\sqrt{3}}{2}$ (C) $\frac{2}{\sqrt{3}}$ (D) $\sqrt{2}$

14. If $\sin 2A = 2 \sin A$, then A is

- (A) 30° (B) 0° (C) 60° (D) 90°

15. $\frac{2 \tan 60^\circ}{1 + \tan^2 60^\circ}$ is equal to

- (A) $\sin 60^\circ$ (B) $\sin 30^\circ$ (C) $\cos 60^\circ$ (D) $\tan 60^\circ$

23.5 APPLICATION OF TRIGONOMETRY

We have so far learnt to define trigonometric ratios of an angle. Also, we have learnt to determine the values of trigonometric ratios for the angles of 30° , 45° and 60° . We also know those trigonometric ratios for angles of 0° and 90° which are well defined. In this section, we will learn how trigonometry can be used to determine the distance between the



Notes

objects or the distance between the objects or the heights of objects by taking examples from day to day life. We shall first define some terms which will be required in the study of heights and distances.

23.5.1 Angle of Elevation

When the observer is looking at an object (P) which is at a greater height than the observer (A), he has to lift his eyes to see the object and an angle of elevation is formed between the line of sight joining the observer's eye to the object and the horizontal line. In Fig. 23.6, A is the observer, P is the object, AP is the line of sight and AB is the horizontal line, then $\angle\theta$ is the angle of elevation.

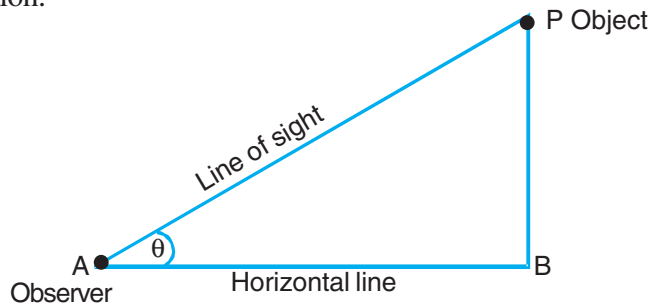

Fig. 23.6

23.5.2 Angle of Depression

When the observer (A) (at a greater height), is looking at an object (at a lesser height), the angle formed between the line of sight and the horizontal line is called an angle of depression. In Fig. 23.7, AP is the line of sight and AK is the horizontal line. Here α is the angle of depression.

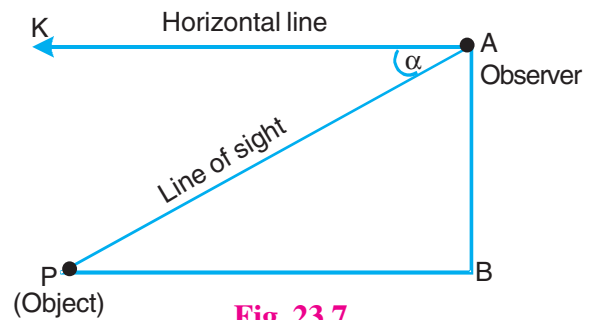

Fig. 23.7

Example 23.16: A ladder leaning against a window of a house makes an angle of 60° with the ground. If the length of the ladder is 6 m, find the distance of the foot of the ladder from the wall.

Solution: Let AC be a ladder leaning against the wall, AB making an angle of 60° with the level ground BC.

Here AC = 6 m ...(Given)

Now in right angled ΔABC ,

$$\frac{BC}{AC} = \cos 60^\circ$$

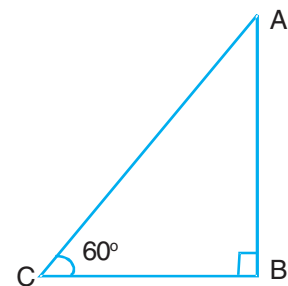

Fig. 23.8



or $\frac{BC}{6} = \frac{1}{2}$

or $BC = \frac{1}{2} \times 6$ or 3 m

Hence, the foot of the ladder is 3 m away from the wall.

Example 23.17: The shadow of a vertical pole is $\frac{1}{\sqrt{3}}$ of its height. Show that the sun's elevation is 60° .

Solution: Let AB be vertical pole of height h units and BC be its shadow.

Then $BC = h \times \frac{1}{\sqrt{3}}$ units

Let θ be the sun's elevation.

Then in right $\triangle ABC$,

$$\tan \theta = \frac{AB}{BC} = \frac{h}{h/\sqrt{3}} = \sqrt{3}$$

or $\tan \theta = \tan 60^\circ$

$\therefore \theta = 60^\circ$

Hence, the sun's elevation is 60° .

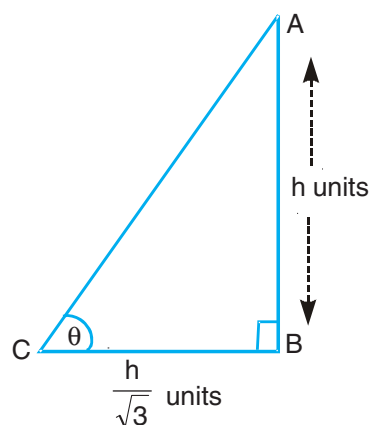

Fig. 23.9

Example 23.18: A tower stands vertically on the ground. The angle of elevation from a point on the ground, which is 30 m away from the foot of the tower is 30° . Find the height of the tower. (Take $\sqrt{3} = 1.73$)

Solution: Let AB be the tower h metres high.

Let C be a point on the ground, 30 m away from B, the foot of the tower

$\therefore BC = 30$ m

Then by question, $\angle ACB = 30^\circ$

Now in right $\triangle ABC$,

$$\frac{AB}{BC} = \tan 30^\circ$$

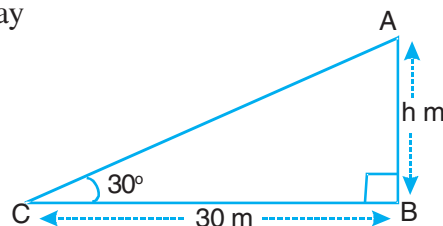

Fig. 23.10



Notes

or $\frac{h}{30} = \frac{1}{\sqrt{3}}$

$\therefore h = \frac{30}{\sqrt{3}}$ m

$= \frac{30}{\sqrt{3}} \times \frac{\sqrt{3}}{\sqrt{3}}$ m

$= 10\sqrt{3}$ m

$= 10 \times 1.73$ m

$= 17.3$ m

Hence, height of the tower is 17.3 m.

Example 23.19: A balloon is connected to a meteorological ground station by a cable of length 100 m inclined at 60° to the horizontal. Find the height of the balloon from the ground assuming that there is no slack in the cable.

Solution: Let A be the position of the balloon, attached to the cable AC of length 100 m. AC makes an angle of 60° with the level ground BC.

Let AB, the height of the balloon be h metres

Now in right $\triangle ABC$,

$\frac{AB}{AC} = \sin 60^\circ$

or $\frac{h}{100} = \frac{\sqrt{3}}{2}$

or $h = 50\sqrt{3}$
 $= 50 \times 1.732$
 $= 86.6$

Hence, the balloon is at a height of 86.6 metres.

Example 23.20: The upper part of a tree is broken by the strong wind. The top of the tree makes an angle of 30° with the horizontal ground. The distance between the base of the tree and the point where it touches the ground is 10 m. Find the height of the tree.

Solution: Let AB be the tree, which was broken at C, by the wind and the top A of the

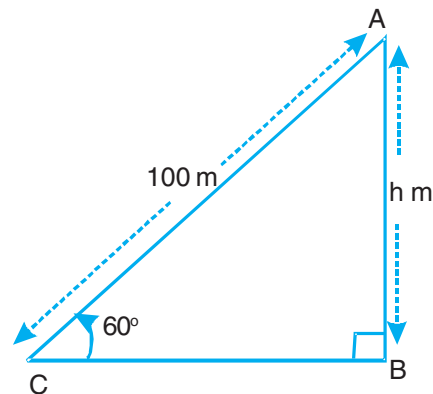

Fig. 23.11



Notes

tree touches the ground at D, making an angle of 30° with BD and $BD = 10$ m.

Let $BC = x$ metres

Now in right $\triangle CBD$,

$$\frac{BC}{BD} = \tan 30^\circ$$

or $\frac{x}{10} = \frac{1}{\sqrt{3}}$

or $x = \frac{10}{\sqrt{3}}$ m ... (i)

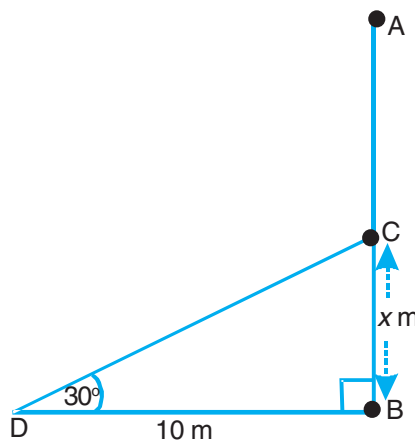

Fig. 23.12

Again in right $\triangle CBD$,

$$\frac{BC}{DC} = \sin 30^\circ$$

or $\frac{x}{DC} = \frac{1}{2}$

or $DC = 2x$

$$= \frac{20}{\sqrt{3}} \text{ m} \quad \dots [\text{By (i)}]$$

$\therefore AC = DC = \frac{20}{\sqrt{3}}$... (ii)

Now height of the tree = $BC + AC$

$$= \left(\frac{10}{\sqrt{3}} + \frac{20}{\sqrt{3}} \right)$$

$$= \frac{30}{\sqrt{3}} \text{ or } 10\sqrt{3} \text{ m}$$

$$= 17.32 \text{ m}$$

Hence height of the tree = 17.32 m

Example 23.21: The shadow of a tower, when the angle of elevation of the sun is 45° is found to be 10 metres longer than when it was 60° . Find the height of the tower.



Notes

Solution: Let AB be the tower h metres high and C and D be the two points where the angles of elevation are 45° and 60° respectively.

Then $CD = 10$ m, $\angle ACB = 45^\circ$ and $\angle ADB = 60^\circ$

Let BD be x metres.

Then $BC = BD + CD = (x + 10)$ m

Now in rt. $\triangle ABC$,

$$\frac{AB}{BC} = \tan 45^\circ$$

or $\frac{h}{x+10} = 1$

$\therefore x = (h - 10)$ m ... (i)

Again in rt $\triangle ABD$,

$$\frac{AB}{BD} = \tan 60^\circ$$

or $\frac{h}{x} = \sqrt{3}$

or $h = \sqrt{3}x$... (ii)

From (i) and (ii), we get

$$h = \sqrt{3}(h - 10)$$

or $h = \sqrt{3}h - 10\sqrt{3}$

or $(\sqrt{3} - 1)h = 10\sqrt{3}$

$\therefore h = \frac{10\sqrt{3}}{\sqrt{3} - 1}$

$$= \frac{10\sqrt{3}}{\sqrt{3} - 1} \times \frac{(\sqrt{3} + 1)}{(\sqrt{3} + 1)} = \frac{10\sqrt{3}(\sqrt{3} + 1)}{2}$$

$$= 5\sqrt{3}(\sqrt{3} + 1) = 15 + 5 \times 1.732 = 15 + 8.66 = 23.66$$

Hence, height of the tower is 23.66 m.

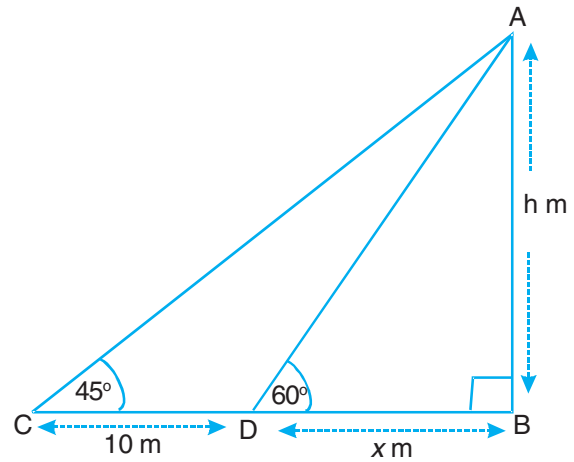

Fig. 23.13



Example 23.22: An aeroplane when 3000 m high passes vertically above another aeroplane at an instant when the angles of elevation of the two aeroplanes from the same point on the ground are 60° and 45° respectively. Find the vertical distance between the two planes.

Solution: Let O be the point of observation.

Let P and Q be the two planes

Then $AP = 3000$ m and $\angle AOQ = 45^\circ$

and $\angle AOP = 60^\circ$

In rt. $\triangle QAO$,

$$\frac{AQ}{AO} = \tan 45^\circ = 1$$

or $AQ = AO$... (i)

Again in rt. $\triangle PAO$,

$$\frac{PA}{AO} = \tan 60^\circ = \sqrt{3}$$

$$\therefore \frac{3000}{AO} = \sqrt{3} \text{ or } AO = \frac{3000}{\sqrt{3}} \text{ ... (ii)}$$

From (i) and (ii), we get

$$AQ = \frac{3000}{\sqrt{3}} \times \frac{\sqrt{3}}{\sqrt{3}} = 1000\sqrt{3} = 1732 \text{ m}$$

$$\therefore PQ = AP - AQ = (3000 - 1732) \text{ m} = 1268 \text{ m}$$

Hence, the required distance is 1268 m.

Example 23.23: The angle of elevation of the top of a building from the foot of a tower is 30° and the angle of elevation of the top of the tower from the foot of the building is 60° . If the tower is 50 m high, find the height of the building.

Solution: Let PQ be the tower 50 m high and AB be the building x m high.

Then $\angle AQB = 30^\circ$ and $\angle PBQ = 60^\circ$

$$\text{In rt. } \triangle ABQ, \frac{x}{BQ} = \tan 30^\circ \text{ ... (i)}$$

$$\text{and in rt. } \triangle PQB, \frac{PQ}{BQ} = \tan 60^\circ$$

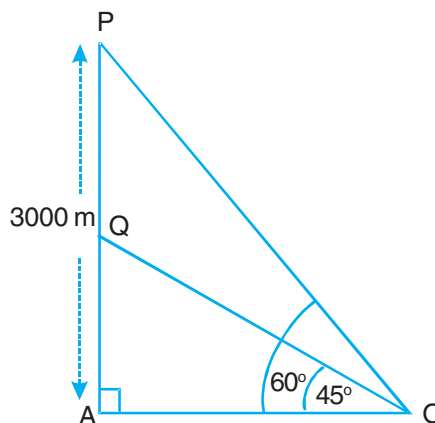

Fig. 23.14



Notes

$$\text{or } \frac{50}{BQ} = \tan 60^\circ \dots(\text{ii})$$

Dividing (i) by (ii), we get,

$$\frac{x}{50} = \frac{\tan 30^\circ}{\tan 60^\circ} = \frac{1}{3}$$

$$\text{or } x = \frac{50}{3} = 16.67$$

Hence, height of the building is 16.67 m.

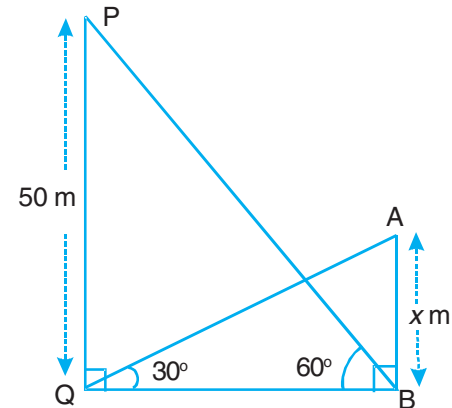

Fig. 23.15

Example 23.24: A person standing on the bank of a river observes that the angle of elevation of the top of a tree standing on the opposite bank is 60° . When he moves 40 metres away from the bank, he finds the angle to be 30° . Find the height of the tree and the width of the river.

Solution: Let AB be a tree of height h metres.

Let $BC = x$ metres represents the width of the river.

Let C and D be the two points where the tree subtends angles of 60° and 30° respectively

In right $\triangle ABC$,

$$\frac{AB}{BC} = \tan 60^\circ$$

$$\text{or } \frac{h}{x} = \sqrt{3}$$

$$\text{or } h = \sqrt{3}x \dots(\text{i})$$

Again in right $\triangle ABD$,

$$\frac{AB}{BD} = \tan 30^\circ$$

$$\text{or } \frac{h}{x+40} = \frac{1}{\sqrt{3}} \dots(\text{ii})$$

From (i) and (ii), we get,

$$\frac{\sqrt{3}x}{x+40} = \frac{1}{\sqrt{3}}$$

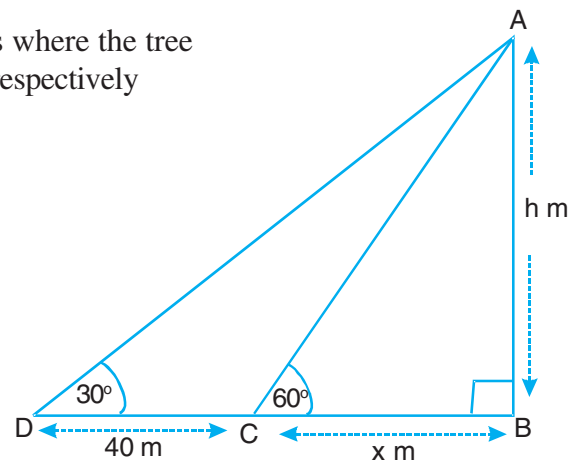

Fig. 23.16



or $3x = x + 40$

or $2x = 40$

$\therefore x = 20$

\therefore From (i), we get

$$h = \sqrt{3} \times 20 = 20 \times 1.732$$

$$= 34.64$$

Hence, width of the river is 20 m and height of the tree is 34.64 metres.

Example 23.25: Standing on the top of a tower 100 m high, Swati observes two cars on the opposite sides of the tower. If their angles of depression are 45° and 60° , find the distance between the two cars.

Solution: Let PM be the tower 100 m high. Let A and B be the positions of the two cars. Let the angle of depression of car at A be 60° and of the car at B be 45° as shown in Fig. 23.17.

Now $\angle QPA = 60^\circ = \angle PAB$

and $\angle RPB = 45^\circ = \angle PBA$

In right $\triangle PMB$,

$$\frac{PM}{MB} = \tan 45^\circ$$

or $\frac{100}{MB} = 1$

or $MB = 100 \text{ m} \quad \dots(i)$

Also in right $\triangle PMA$,

$$\frac{PM}{MA} = \tan 60^\circ$$

or $\frac{100}{MA} = \sqrt{3}$

$\therefore MA = \frac{100}{\sqrt{3}}$

$$= \frac{100\sqrt{3}}{3}$$

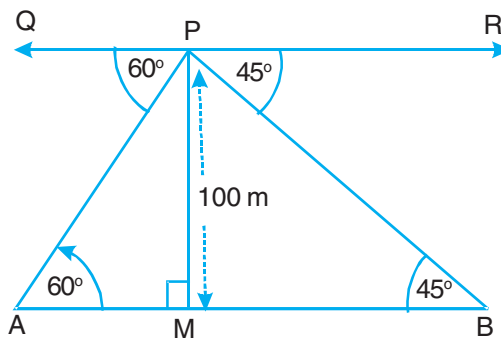

Fig. 23.17



Notes

$$= \frac{100 \times 1.732}{3}$$

$$= 57.74$$

$$\therefore MA = 57.74 \text{ m} \quad \dots(\text{ii})$$

Hence, the distance between the two cars

$$= MA + MB$$

$$= (57.74 + 100) \text{ m} \quad [\text{By (i) and (ii)}]$$

$$= 157.74 \text{ m}$$

Example 23.26: Two pillars of equal heights are on either side of a road, which is 100 m wide. At a point on the road between the pillars, the angles of elevation of the top of the pillars are 60° and 30° respectively. Find the position of the point between the pillars and the height of each pillar.

Solution: Let AB and CD be two pillars each of height h metres. Let O be a point on the road. Let $BO = x$ metres, then

$$OD = (100 - x) \text{ m}$$

By question, $\angle AOB = 60^\circ$ and $\angle COD = 30^\circ$

In right $\triangle ABO$,

$$\frac{AB}{BO} = \tan 60^\circ$$

or $\frac{h}{x} = \sqrt{3}$

or $h = \sqrt{3} x \quad \dots(\text{i})$

In right $\triangle CDO$,

$$\frac{CD}{OD} = \tan 30^\circ$$

or $\frac{h}{100 - x} = \frac{1}{\sqrt{3}} \quad \dots(\text{ii})$

From (i) and (ii), we get

$$\frac{\sqrt{3}x}{100 - x} = \frac{1}{\sqrt{3}}$$

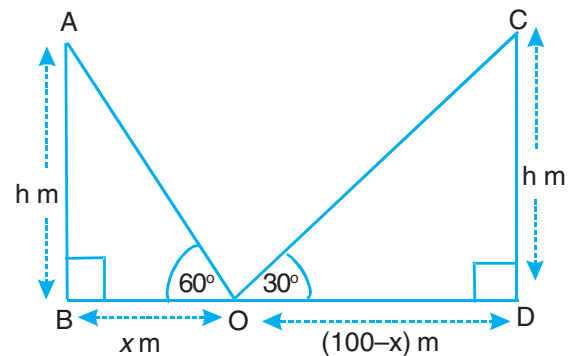

Fig. 23.18



or $3x = 100 - x$

or $4x = 100$

$\therefore x = 25$

\therefore From (i), we get $h = \sqrt{3} \times 25 = 1.732 \times 25$ or 43.3

\therefore The required point from one pillar is 25 metres and 75 m from the other.

Height of each pillar = 43.3 m.

Example 23.27: The angle of elevation of an aeroplane from a point on the ground is 45° . After a flight of 15 seconds, the elevation changes to 30° . If the aeroplane is flying at a constant height of 3000 metres, find the speed of the plane.

Solution: Let A and B be two positions of the plane and let O be the point of observation. Let OCD be the horizontal line.

Then $\angle AOC = 45^\circ$ and $\angle BOD = 30^\circ$

By question, $AC = BD = 3000$ m

In rt $\triangle ACO$,

$$\frac{AC}{OC} = \tan 45^\circ$$

or $\frac{3000}{OC} = 1$

or $OC = 3000$ m ... (i)

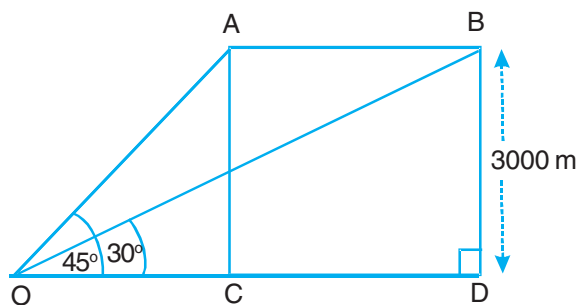

Fig. 23.19

In rt $\triangle BDO$,

$$\frac{BD}{OD} = \tan 30^\circ$$

or $\frac{3000}{OC + CD} = \frac{1}{\sqrt{3}}$

or $3000\sqrt{3} = 3000 + CD$... [By (i)]

$$\begin{aligned} \text{or } CD &= 3000(\sqrt{3} - 1) \\ &= 3000 \times 0.732 \\ &= 2196 \end{aligned}$$

\therefore Distance covered by the aeroplane in 15 seconds = $AB = CD = 2196$ m



Notes

$$\begin{aligned} \therefore \text{Speed of the plane} &= \left(\frac{2196}{15} \times \frac{60 \times 60}{1000} \right) \text{ km/h} \\ &= 527.04 \text{ km/h} \end{aligned}$$

Example 23.28: The angles of elevation of the top of a tower from two points P and Q at distances of a and b respectively from the base and in the same straight line with it are complementary. Prove that the height of the tower is \sqrt{ab} .

Solution: Let AB be the tower of height h , P and Q be the given points such that $PB = a$ and $QB = b$.

Let $\angle APB = \alpha$ and $\angle AQB = 90^\circ - \alpha$

Now in rt $\triangle ABQ$,

$$\frac{AB}{QB} = \tan(90^\circ - \alpha)$$

$$\text{or } \frac{h}{b} = \cot \alpha \quad \dots(i)$$

and in rt $\triangle ABP$,

$$\frac{AB}{PB} = \tan \alpha$$

$$\text{or } \frac{h}{a} = \tan \alpha \quad \dots(ii)$$

Multiplying (i) and (ii), we get

$$\frac{h}{b} \times \frac{h}{a} = \cot \alpha \cdot \tan \alpha = 1$$

$$\text{or } h^2 = ab$$

$$\text{or } h = \sqrt{ab}$$

Hence, height of the tower is \sqrt{ab} .

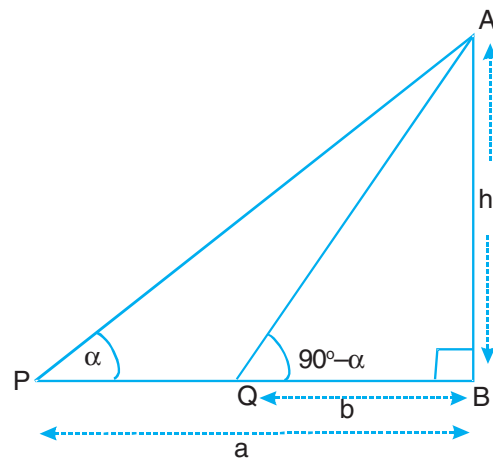

Fig. 23.20



CHECK YOUR PROGRESS 23.2

1. A ladder leaning against a vertical wall makes an angle of 60° with the ground. The foot of the ladder is at a distance of 3 m from the wall. Find the length of the ladder.



2. At a point 50 m away from the base of a tower, an observer measures the angle of elevation of the top of the tower to be 60° . Find the height of the tower.
3. The angle of elevation of the top of the tower is 30° , from a point 150 m away from its foot. Find the height of the tower.
4. The string of a kite is 100 m long. It makes an angle of 60° with the horizontal ground. Find the height of the kite, assuming that there is no slack in the string.
5. A kite is flying at a height of 100 m from the level ground. If the string makes an angle of 60° with a point on the ground, find the length of the string assuming that there is no slack in the string.
6. Find the angle of elevation of the top of a tower which is $100\sqrt{3}$ m high, from a point at a distance of 100 m from the foot of the tower on a horizontal plane.
7. A tree 12 m high is broken by the wind in such a way that its tip touches the ground and makes an angle of 60° with the ground. At what height from the ground, the tree is broken by the wind?
8. A tree is broken by the storm in such way that its tip touches the ground at a horizontal distance of 10 m from the tree and makes an angle of 45° with the ground. Find the height of the tree.
9. The angle of elevation of a tower at a point is 45° . After going 40 m towards the foot of the tower, the angle of elevation becomes 60° . Find the height of the tower.
10. Two men are on either side of a cliff which is 80 m high. They observe the angles of elevation of the top of the cliff to be 30° and 60° respectively. Find the distance between the two men.
11. From the top of a building 60 m high, the angles of depression of the top and bottom of a tower are observed to be 45° and 60° respectively. Find the height of the tower and its distance from the building.
12. A ladder of length 4 m makes an angle of 30° with the level ground while leaning against a window of a room. The foot of the ladder is kept fixed on the same point of the level ground. It is made to lean against a window of another room on its opposite side, making an angle of 60° with the level ground. Find the distance between these rooms.
13. At a point on the ground distant 15 m from its foot, the angle of elevation of the top of the first storey is 30° . How high the second storey will be, if the angle of elevation of the top of the second storey at the same point is 45° ?
14. An aeroplane flying horizontal 1 km above the ground is observed at an elevation of 60° . After 10 seconds its elevation is observed to be 30° . Find the speed of the aeroplane.



Notes

15. The angle of elevation of the top of a building from the foot of a tower is 30° and the angle of elevation of the top of the tower from the foot of the building is 60° . If the tower is 50 m high, find the height of the building.



LET US SUM UP

- Table of values of Trigonometric Ratios

θ	0°	30°	45°	60°	90°
Trig. ratio					
$\sin \theta$	0	$\frac{1}{2}$	$\frac{1}{\sqrt{2}}$	$\frac{\sqrt{3}}{2}$	1
$\cos \theta$	1	$\frac{\sqrt{3}}{2}$	$\frac{1}{\sqrt{2}}$	$\frac{1}{2}$	0
$\tan \theta$	0	$\frac{1}{\sqrt{3}}$	1	$\sqrt{3}$	Not defined
$\cot \theta$	Not defined	$\sqrt{3}$	1	$\frac{1}{\sqrt{3}}$	0
$\operatorname{cosec} \theta$	Not defined	2	$\sqrt{2}$	$\frac{2}{\sqrt{3}}$	1
$\sec \theta$	1	$\frac{2}{\sqrt{3}}$	$\sqrt{2}$	2	Not defined

Supportive website:

- <http://www.wikipedia.org>
- <http://mathworld.wolfram.com>



TERMINAL EXERCISE

- Find the value of each of the following:
 - $4 \cos^2 60^\circ + 4 \sin^2 45^\circ - \sin^2 30^\circ$
 - $\sin^2 45^\circ - \tan^2 45^\circ + 3(\sin^2 90^\circ + \tan^2 30^\circ)$



$$(iii) \frac{5 \sin^2 30^\circ + \cos^2 45^\circ - 4 \tan^2 30^\circ}{2 \sin^2 30^\circ \cos^2 30^\circ + \tan 45^\circ}$$

$$(iv) \frac{\cot 45^\circ}{\sec 30^\circ + \operatorname{cosec} 30^\circ}$$

2. Prove each of the following:

$$(i) 2 \cot^2 30^\circ - 2 \cos^2 60^\circ - \frac{3}{4} \sin^2 45^\circ - 4 \sec^2 30^\circ = -\frac{5}{24}$$

$$(ii) 2 \sin^2 30^\circ + 2 \tan^2 60^\circ - 5 \cos^2 45^\circ = 4$$

$$(iii) \cos 60^\circ \cos 45^\circ + \sin 60^\circ \sin 45^\circ = \sin 45^\circ \cos 30^\circ + \cos 45^\circ \sin 30^\circ$$

$$(iv) \frac{\cot 30^\circ \cot 60^\circ - 1}{\cot 30^\circ + \cot 60^\circ} = \cot 90^\circ$$

3. If $\theta = 30^\circ$, verify that

$$(i) \sin 2\theta = 2 \sin \theta \cos \theta$$

$$(ii) \cos 2\theta = 1 - 2 \sin^2 \theta$$

$$(iii) \tan 2\theta = \frac{2 \tan \theta}{1 - \tan^2 \theta}$$

4. If $A = 60^\circ$ and $B = 30^\circ$, verify that

$$(i) \sin (A + B) \neq \sin A + \sin B$$

$$(ii) \sin (A + B) = \sin A \cos B + \cos A \sin B$$

$$(iii) \cos (A - B) = \cos A \cos B + \sin A \sin B$$

$$(iv) \cos (A + B) = \cos A \cos B - \sin A \sin B$$

$$(v) \tan A = \frac{\sqrt{1 - \cos^2 A}}{\cos A}$$

5. Using the formula $\cos (A - B) = \cos A \cos B + \sin A \sin B$, find the value of $\cos 15^\circ$.

6. If $\sin (A + B) = 1$ and $\cos (A - B) = \frac{\sqrt{3}}{2}$, $0^\circ < A + B \leq 90^\circ$, $A > B$, find A and B .

7. An observer standing 40 m from a building observes that the angle of elevation of the top and bottom of a flagstaff, which is surmounted on the building are 60° and 45° respectively. Find the height of the tower and the length of the flagstaff.



Notes

8. From the top of a hill, the angles of depression of the consecutive kilometre stones due east are found to be 60° and 30° . Find the height of the hill.
9. From the top of a 7 m high building, the angle of elevation of the top of a cable tower is 60° and the angle of depression of its foot is 45° . Find the height of the tower.
10. A man on the top of a tower on the sea shore finds that a boat coming towards him takes 10 minutes for the angle of depression to change from 30° to 60° . How soon will the boat reach the sea shore?
11. Two boats approach a light-house from opposite directions. The angle of elevation of the top of the lighthouse from the boats are 30° and 45° . If the distance between these boats be 100 m, find the height of the lighthouse.
12. The shadow of a tower standing on a level ground is found to be $45\sqrt{3}$ m longer when the sun's altitude is 30° than when it was 60° . Find the height of the tower.
13. The horizontal distance between two towers is 80 m. The angle of depression of the top of the first tower when seen from the top of the second tower is 30° . If the height of the second tower is 160 m, find the height of the first tower.
14. From a window, 10 m high above the ground, of a house in a street, the angles of elevation and depression of the top and the foot of another house on opposite side of the street are 60° and 45° respectively. Find the height of the opposite house (Take $\sqrt{3} = 1.73$)
15. A statue 1.6 m tall stands on the top of a pedestal from a point on the ground, the angle of elevation of the top of the statue is 60° and from the same point, the angle of elevation of the top of the pedestal is 45° . Find the height of the pedestal.



ANSWERS TO CHECK YOUR PROGRESS

23.1

1. (i) $\frac{5}{4}$ (ii) $\frac{5}{2}$ (iii) 0 (iv) 2 (v) 0 (vi) $\frac{67}{12}$

5. $\sin 30^\circ = \frac{1}{2}$, $\cos 30^\circ = \frac{\sqrt{3}}{2}$

6. $\frac{\sqrt{3}-1}{2\sqrt{2}}$

7. $A = 45^\circ$ and $B = 15^\circ$



8. $A = 30^\circ$ and $B = 15^\circ$
 9. $QR = 5\sqrt{3}$ and $PR = 10$ cm
 10. $\angle A = 60^\circ$ and $\angle C = 30^\circ$

11. $\frac{\sqrt{3}}{2}$

12. $x = 10^\circ$

13. C

14. B

15. A

23.2

- | | | |
|--------------|-----------------|---------------|
| 1. 6 m | 2. 86.6 m | 3. 86.6 m |
| 4. 86.6 m | 5. 115.46 m | 6. 60° |
| 7. 5.57 m | 8. 24.14 m | 9. 94.64 m |
| 10. 184.75 m | 11. 25.35 m | 12. 5.46 m |
| 13. 6.34 m | 14. 415.66 km/h | 15. 16.67 m |



ANSWERS TO TERMINAL EXERCISE

- | | | | |
|-----------------------------------|--------------------------------------|------------------------|---------------------------------------|
| 1. (i) $\frac{11}{4}$ | (ii) $\frac{7}{2}$ | (iii) $\frac{40}{121}$ | (iv) $\frac{\sqrt{3}}{2(\sqrt{3}+1)}$ |
| 5. $\frac{\sqrt{3}+1}{2\sqrt{2}}$ | 6. $A = 60^\circ$ and $B = 30^\circ$ | 7. 40m , 29.28 m | |
| 8. 433 m | 9. 19.124 m | 10. 5 minutes | |
| 11. 36.6 m | 12. 67.5 m | 13. 113.8 m | |
| 14. 27.3 m | 15. 2.18656 m | | |



Secondary Course Mathematics

Practice Work-Trigonometry

Maximum Marks: 25

Time : 45 Minutes

Instructions:

- Answer all the questions on a separate sheet of paper.
- Give the following informations on your answer sheet
Name
Enrolment number
Subject
Topic of practice work
Address
- Get your practice work checked by the subject teacher at your study centre so that you get positive feedback about your performance.

Do not send practice work to National Institute of Open Schooling

1. In the adjoining figure, the value of $\sin A$ is

- (A) $\frac{5}{13}$
(B) $\frac{12}{13}$
(C) $\frac{5}{12}$
(D) $\frac{13}{12}$

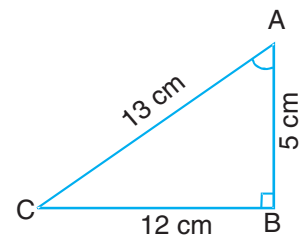

1

2. If $4 \cot A = 3$, then value of $\frac{\sin A - \cos A}{\sin A + \cos A}$ is

1



- (A) $\frac{1}{7}$ (B) $\frac{6}{7}$
- (C) $\frac{5}{6}$ (D) $\frac{3}{4}$
3. The value of $\sec 30^\circ$ is 1
- (A) 2 (B) $\frac{\sqrt{3}}{2}$
- (C) $\frac{2}{\sqrt{3}}$ (D) $\sqrt{2}$
4. In $\triangle ABC$, right angled at B, if $AB = 6$ cm and $AC = 12$ cm, then $\angle A$ is 1
- (A) 60°
- (B) 30°
- (C) 45°
- (D) 15°
5. The value of 1
- $$\frac{\sin 36^\circ}{2 \cos 54^\circ} - \frac{2 \sec 41^\circ}{3 \operatorname{cosec} 49^\circ}$$
- is
- (A) -1
- (B) $\frac{1}{6}$
- (C) $-\frac{1}{6}$
- (D) 1
6. If $\sin A = \frac{1}{2}$, show that 2
- $$3 \cos A - 4 \cos^3 A = 0$$
7. Using the formula $\sin (A - B) = \sin A \cos B - \cos A \sin B$, find the value of $\sin 15^\circ$. 2
8. Find the value of 2
- $$\tan 15^\circ \tan 25^\circ \tan 60^\circ \tan 65^\circ \tan 75^\circ$$



Notes

9. Show that $\sqrt{\frac{1 + \sin A}{1 - \sin A}} = \sec A + \tan A$ 2
10. If $\sin^2 \theta + \sin \theta = 1$, then show that 2
 $\cos^2 \theta + \cos^4 \theta = 1$
11. Prove that $\frac{\cot A + \operatorname{cosec} A - 1}{\cot A - \operatorname{cosec} A + 1} = \frac{1 + \cos A}{\sin A}$ 4
12. An observer standing 40 m from a building notices that the angles of elevation of the top and the bottom of a flagstaff surmounted on the building are 60° and 45° respectively. Find the height of the building and the flag staff. 6

MODULE 6

Statistics

*The modern society is essentially data oriented. It is difficult to imagine any facet of our life untouched in newspapers, advertisements, magazines, periodicals and other forms of publicity over radio, television etc. These data may relate to cost of living, mortality rate, literacy rate, cricket averages, rainfall of different cities, temperatures of different towns, expenditures in various sectors of a five year plan and so on. It is, therefore, essential to know how to extract 'meaningful' information from such data. This extraction of useful or meaningful information is studied in the branch of mathematics called **statistics**.*

In the lesson on "Data and their Representations" the learner will be introduced to different types of data, collection of data, presentation of data in the form of frequency distributions, cumulative frequency tables, graphical representations of data in the form of bar charts (graphs), histograms and frequency polygons.

Sometimes, we are required to describe the data arithmetically, like describing mean age of a class of students, mean height of a group of students, median score or modal shoe size of a group. Thus, we need to find certain measures which summarise the main features of the data. In lesson on "measures of Central Tendency", the learner will be introduced to some measures of central tendency i.e., mean, median, mode of ungrouped data and mean of grouped data.

In the lesson on "Introduction to Probability", the learner will get acquainted with the concept of theoretical probability as a measure of uncertainty, through games of chance like tossing a coin, throwing a die etc.